

Waynesville Engineering Program 2021-2022

- **INTRODUCTION TO ENGINEERING DESIGN**
- **AEROSPACE ENGINEERING**
- **DIGITAL ELECTRONICS**
- **PRINCIPLES OF ENGINEERING**
- **ADVANCED DESIGN & ROBOTICS**

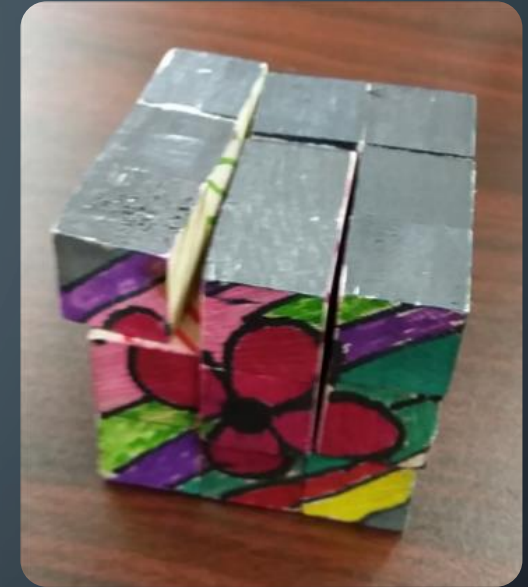
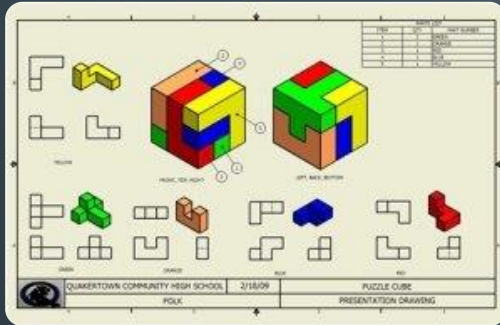

STUDENT CENTERED PROJECTS

Puzzle Cube

Halloween Project

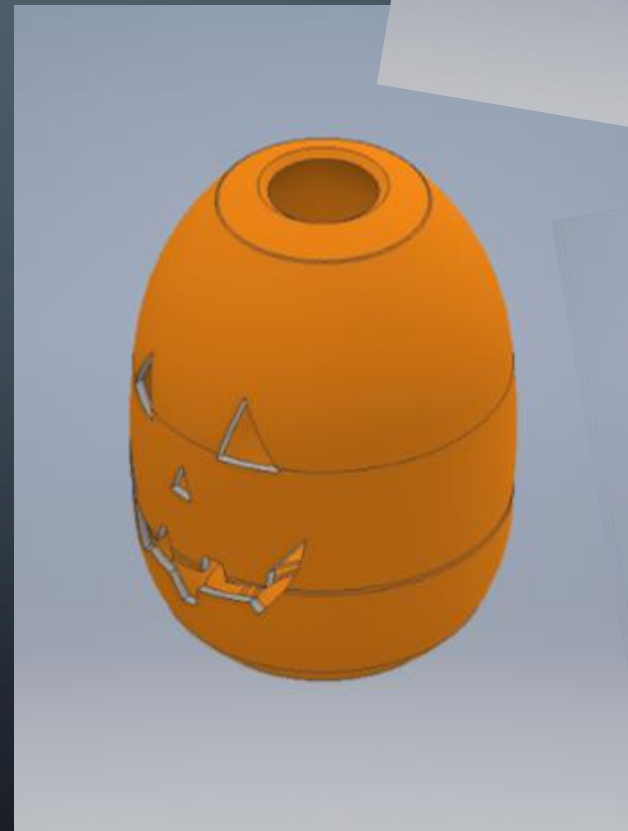
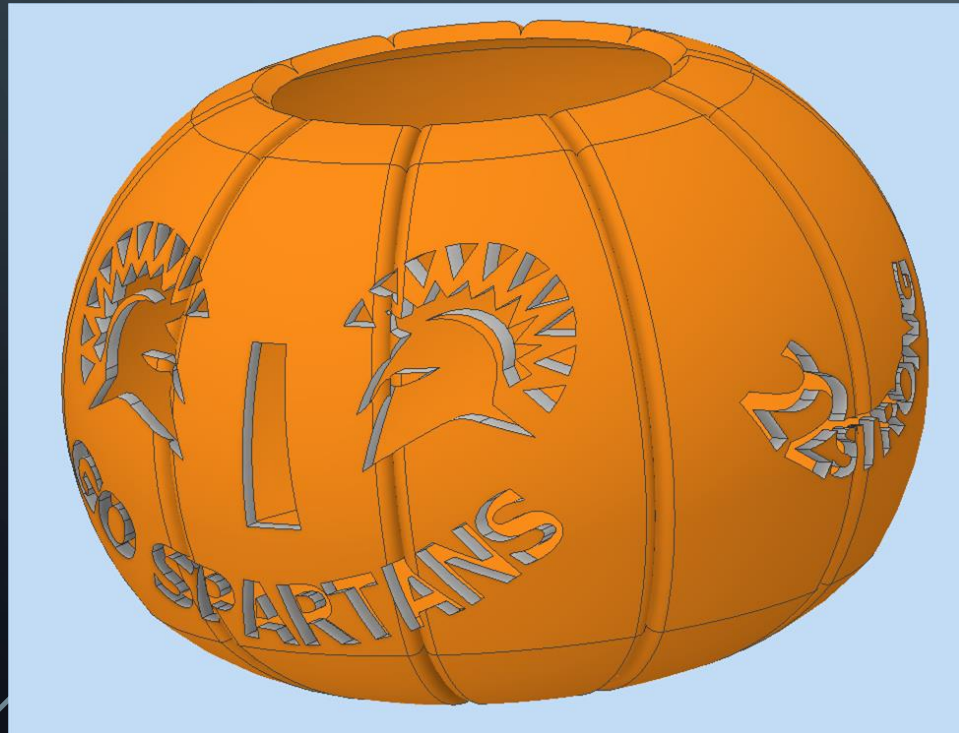
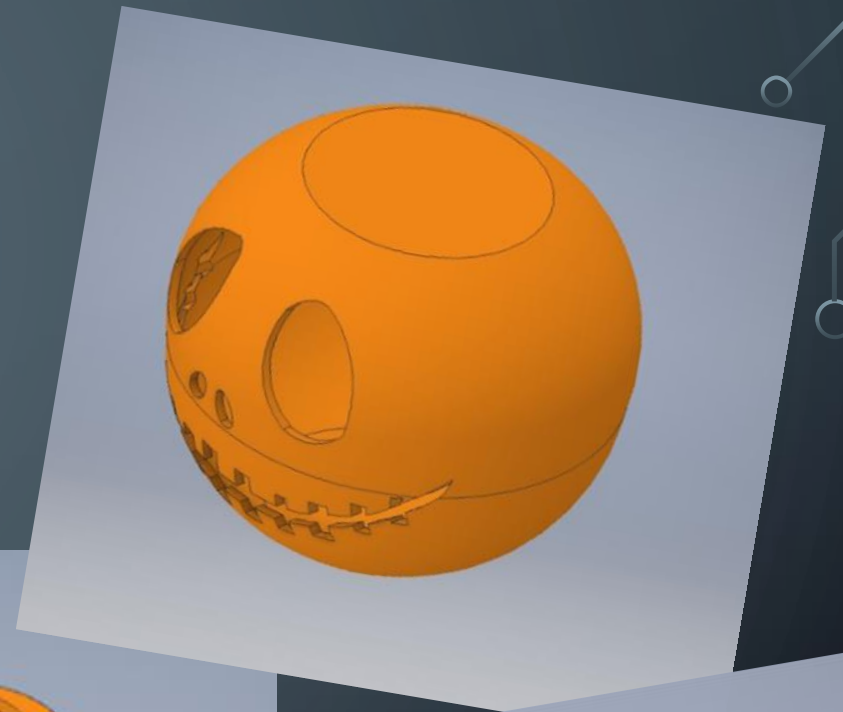
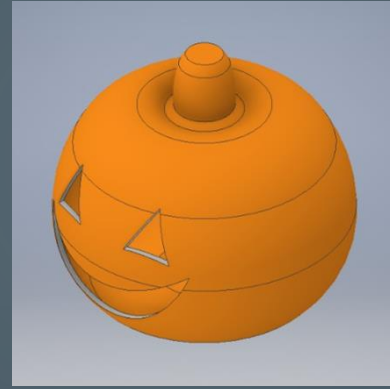

Holiday Project

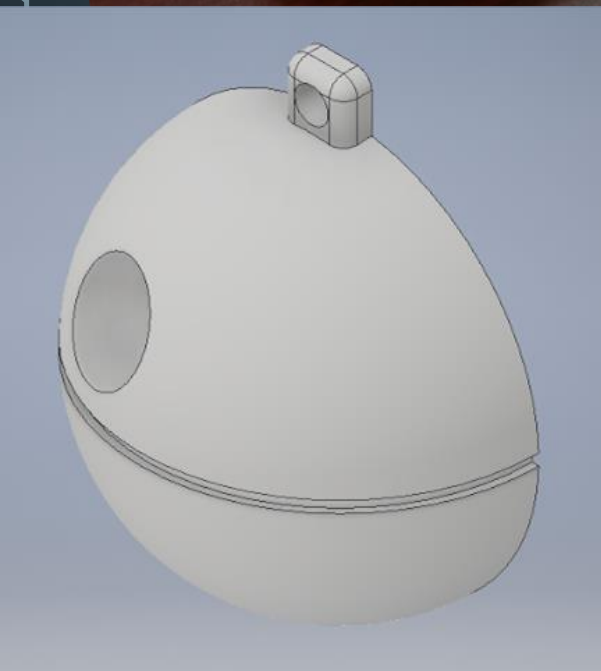

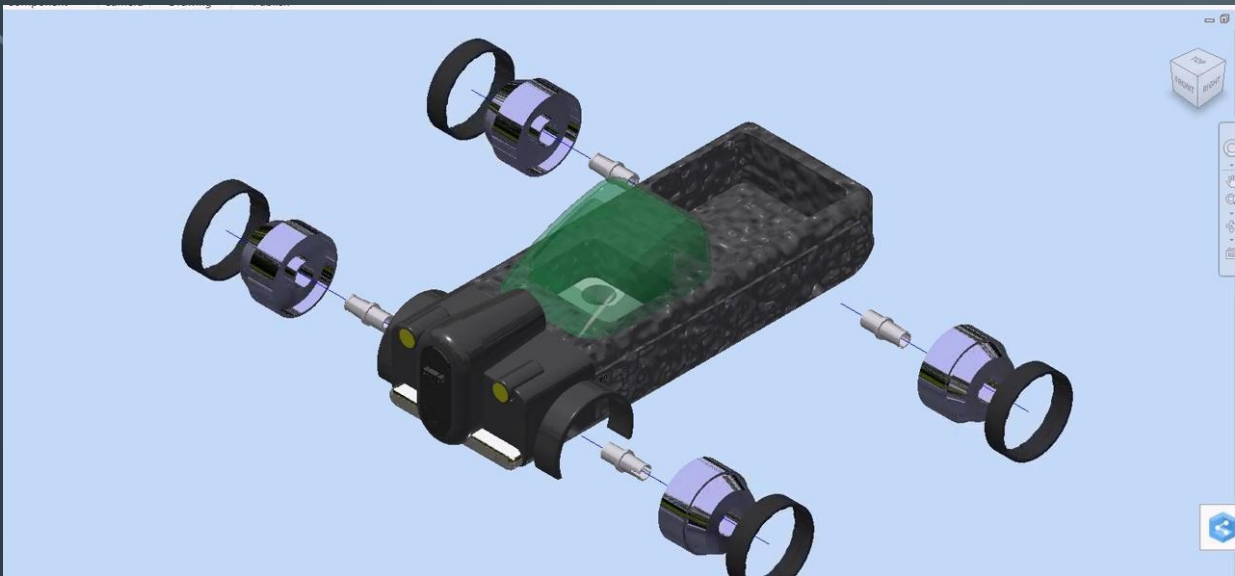

IED Videos

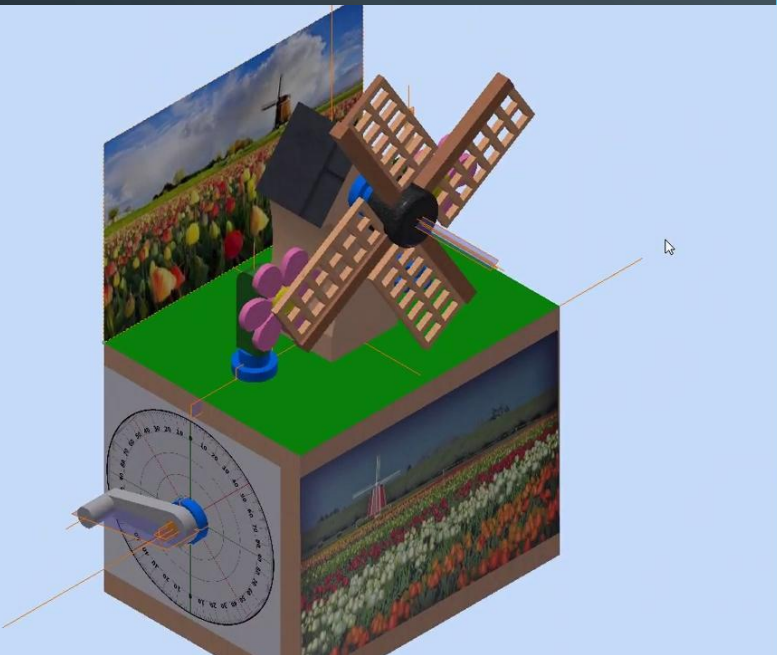

Aerospace Engineering (AERO)

- Engineering Design Process (EDP)
- Newton's Laws of Motion
- Lift, Drag, Thrust, & Weight
- Angle of Attack
- Center of Gravity (COG) & Moments
- Kepler's Elements (Orbital Mechanics)
- Computational Thinking & Computer Programming
- Propulsion
- Career Opportunities & Pathways in the Field of Aerospace

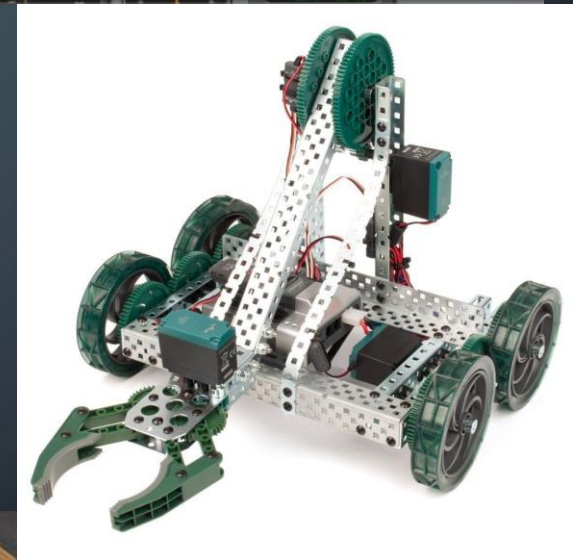

AERO Videos

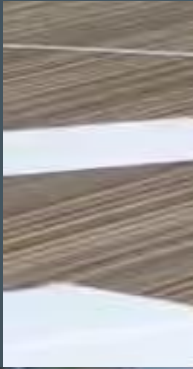

Digital Electronics

New in 2021-22

- From smartphones to appliances, digital circuits are all around us. This course provides a foundation for students who are interested in electrical engineering, electronics, or circuit design. Students study topics such as combinational and sequential logic and are exposed to circuit design tools used in industry, including logic gates, integrated circuits, and programmable logic devices.

Principles of Engineering (POE)

- Engineering Design Process (EDP)
- Newton's Laws of Motion
- Work, Torque, & Power
- Ohm's Law: $V = IR$
- Moments & Torque
- Vectors, Forces, and Statics
- Trigonometry: SOH-CAH-TOA
- Computational Thinking
- Combined Gas Law
- Mechanical Advantage

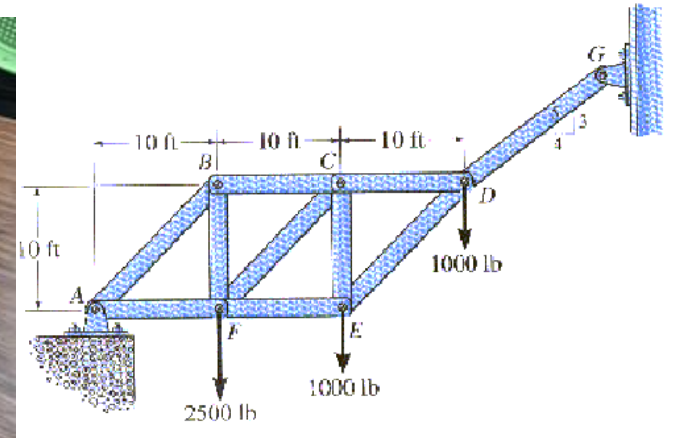
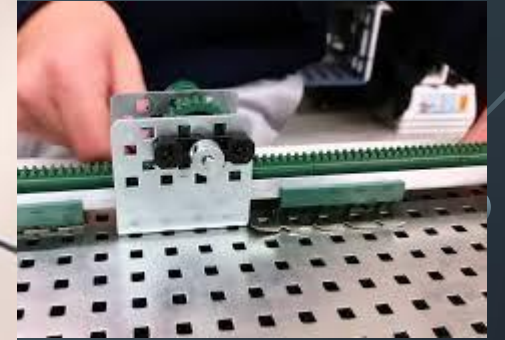
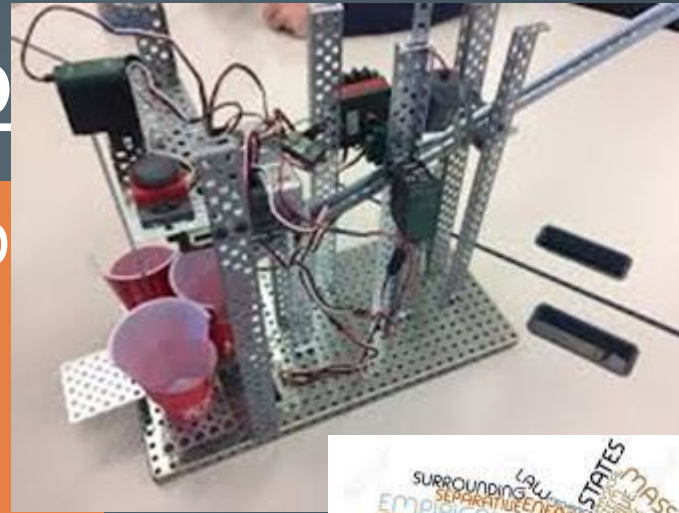

POE Videos

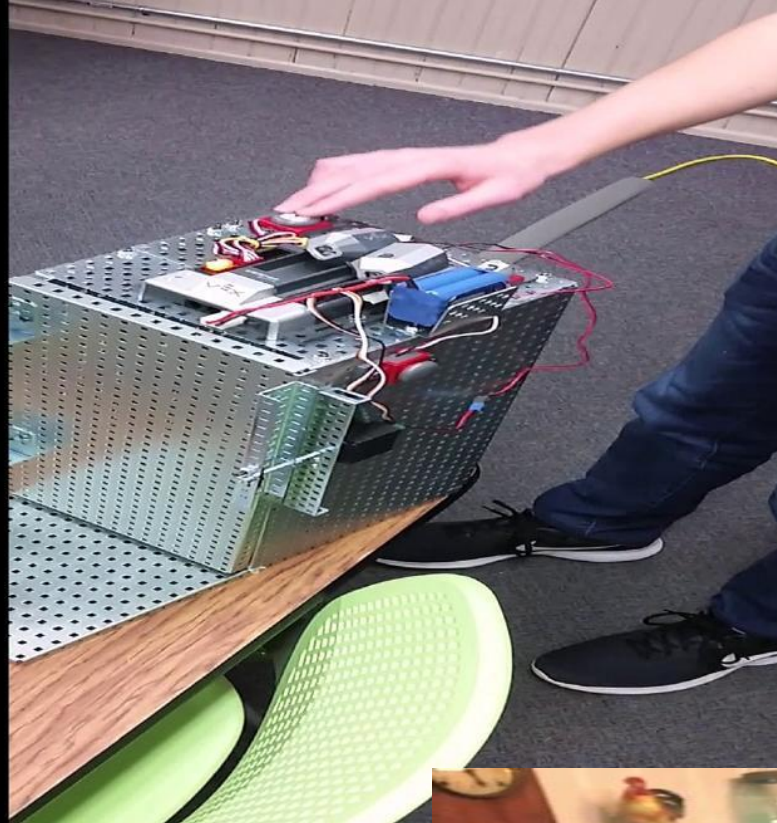
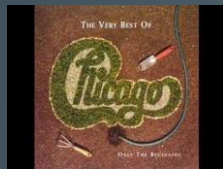

Advanced Design & Robotics (ADR)

New in 2020-21

- This project/problem-based class is driven by individual students' interests and where they think they want to go beyond high school.
- Students will identify multiple real-world problems/challenges and then use their engineering abilities combined with the engineering design process to develop solutions.
- Requirements (2 of following 3):
 - Students must have taken at least two high school engineering classes (POE required)
 - Students must be in either 11th or 12th grade
 - Students must have Mr. Otto's permission to take the class



ABOUT MR. OTTO

4th Year at Waynesville Schools

- Taught Social Studies for 1.5 years
- 4th Year with PLTW

Education

- 1999: BA History
- 2011: AS MET
- 2015: BS MET (Mechanical Engineering)
- 2018- Present: Masters in Education (CI) – ongoing
 - 2019: STEM Certificate
- Certifications
 - ODE *Highly Qualified*: Social Studies, Math, Physics
 - PLTW: DM, AR, IED, POE, AERO

ABOUT MR. OTTO

- Family
 - Married with 3 year old & newborn daughter
 - Adeline was born June 13, 2017
 - NEW ADDITION ARRIVED September 2, 2020
 - 3 Brothers...10 nieces and nephews
- Engineering Experience:
 - CAD Detailer in Aerospace
 - Packaging & Plastics Testing, Research, & Development
 - Mechanical Design
 - Otto Brothers & Otto Industries
- Interests / Hobbies
 - Home Renovation/Design & Sustainability
 - Invention & Innovation
 - Outdoor activities (gardening, hiking, sports, camping, etc.)



Industry Recognized Credentials

Current Offerings:

- Autodesk
 - Inventor
 - AutoCAD
 - Revit
 - Fusion 360
- SolidWorks

Coming Soon: Would you be interested in?

- Lean Six Sigma
 - Yellow & Green Belt
- Allen Bradley and Siemens PLC
- ASQ Certified Quality Inspector
- Certified Additive Manufacturing Fundamentals (CAM-F) AND Certified Drafter Mechanical
- Leadership

Question about the Engineering Program?

Talk to Mr. Otto in the Media Center...OR

send an email to

nik.otto@mywccc.org

Waynesville Engineering Program 2021-2022

- INTRODUCTION TO ENGINEERING DESIGN
- AEROSPACE ENGINEERING
- DIGITAL ELECTRONICS
- PRINCIPLES OF ENGINEERING
- ADVANCED DESIGN & ROBOTICS

Talk to Mr. Otto in the Media Center...OR

send an email to nik.otto@mywccc.org